

Burners



Dual fuel burners

EXDF - (E3611 rev. 01 - 22/06/2016)

GENERAL WARNINGS:



■ All installation, maintenance, ignition and setting must be performed by qualified staff, respecting the norms present at the time and place of the installation.

■ To avoid damage to people and things, it is essential to observe all the points indicated in this handbook. The reported indications do not exonerate the Client/User from observing general or specific laws concerning accidents and environmental safeguarding.

■ The operator must wear proper DPI clothing (shoes, helmets...) and respect the general safety, prevention and precaution norms.

■ To avoid the risks of burns or high voltage electrocution, the operator must avoid all contact with the burner and its control devices during the ignition phase and while it is running at high temperatures.

■ All ordinary and extraordinary maintenance must be performed when the system is stopped.

■ To assure correct and safe use of the combustion plant, it is of extreme importance that the contents of this document be brought to the attention of and be meticulously observed by all personnel in charge of controlling and working the devices.

■ The functioning of a combustion plant can be dangerous and cause injuries to persons or damage to equipment. Every burner must be provided with certified combustion safety and supervision devices.

■ The burner must be installed correctly to prevent any type of accidental/undesired heat transmission from the flame to the operator or the equipment.

■ The performances indicated in this technical document regarding the range of products are a result of experimental tests carried out at ESA-PYRONICS. The tests have been performed using ignition systems, flame detectors and supervisors developed by ESA-PYRONICS. The respect of the above mentioned functioning conditions cannot be guaranteed if equipment, which is not present in the ESA-PYRONICS catalogue, is used.

DISPOSAL:



To dispose of the product, abide by the local legislations regarding it.

GENERAL NOTES:



■ In accordance to the internal policy of constant quality improvement, ESA-PYRONICS reserves the right to modify the technical characteristics of the present document at any time and without warning.

■ It is possible to download technical sheets which have been updated to the latest revision from the www.esapyronics.com website.

■ The EXDF products have been designed, manufactured and tested according to the most correct construction practices and following the applicable requirements described in **UNI EN 746-2-2010** "Industrial heating process equipment - Part 2: Safety requirements for combustion and for the handling and processing of fuels". We emphasize that the burners described in this data sheet **are provided as independent units and are excluded from the scope of the Machine Directive 2006/42/EC** not having any mobile items that are not exclusively manual.

■ Certified in conformity with the **UNI EN ISO 9001** Norm by DNV GL.

CERTIFICATIONS:



The products conform to the requests for the Euroasia market (Russia, Belarus and Kazakhstan).

CONTACTS / SERVICE:



Headquarters:

Esa S.p.A.
Via Enrico Fermi 40
24035 Curno (BG) - Italy
Tel +39.035.6227411
Fax +39.035.6227499
esa@esacombustion.it

International Sales:

Pyronics International s.a.
Zoning Industriel, 4ème rue
B-6040 Jumet - Belgium
Tel +32.71.256970
Fax +32.71.256979
marketing@pyronics.be

www.esapyronics.com

The EXDF burners are dual “fuel nozzle mixing” burners with refractory blocks. They can burn all types of commercial non-corrosive gases or oils with maximum viscosity of 3 ° E. The fuel and the combustion air are mixed at the point of ignition within the refractory cone avoiding the danger of backfiring. The characteristics of the refractory block are such as to allow excellent flame stability and remarkable flow ratio. All the burners of the EXDF series can operate with stoichiometric combustion fuel ratios or with excess air while maintaining a remarkable stability of the flame.

APPLICATIONS

- Kilns for ceramic firing
- Sanitary firing furnaces
- Forging furnaces
- Annealing furnaces
- Reheating furnaces
- Melting furnaces
- Drying furnaces.
- Incenerators
- Furnaces for metal, resin and polymer treatment
- Hot air generators

CHARACTERISTICS

GENERAL:

- Oil functioning capacity: from 100 to 1650 kW
- Gas functioning capacity: from 90 to 1450 kW
- Functioning with preheated air up to: 450°C
- Air and gas pressure to the burner: 70 mbar
- Oil pressure to the burner: 2 bar
- Operation with various types of gases:
CH₄/LPG/Propane/etc...
- Functioning with various types of maximum viscosity oils: 3°E
- Flow ratio with gas operation: 8÷1
- Flow ration with oil operation: 6÷1
- Separate air , gas and oil inlets, nozzle mixing, no flash backs.
- Modular design to facilitate assembly, maintenance and cleaning.

MATERIAL COMPOSITION:

- Mixer body and air/gas collector: Cast iron G25
- Plate: Cast iron G25
- Fuel lance: AISI 304



F3611I03



F3611I04

IGNITION AND DETECTION

The EXDF burners must always be ignited with a DSP electrode or pilot burner in compliance with the EN746 Norm. The pilot burner must be excluded after ignition of the main burner and therefore ignition must take place via a photocell.

Provide a cooling line for ignition electrode (copper pipe \varnothing 8) and for the photocell in case it is mounted on refractory block housing. The adoption of flame control systems is strongly recommended in all systems operating at temperatures below 750 ° C (UNI EN746-2).

Model	Ignition with pilot burner		Ignition with electrode	
	Ignition	Detection	Ignition	Detection
12 EXDF	P64PBC-FR	UV-2	DSP-1	UV-2
16 EXDF	P64PBC-FR	UV-2	DSP-2	UV-2
24 EXDF	P86PBC-FR	UV-2	DSP-3	UV-2
32 EXDF	P86PBC-FR	UV-2	DSP-3	UV-2
48 EXDF	P86PBC-FR	UV-2	DSP-4	UV-2

CAPACITY PARAMETERS AND FLAME LENGTH

The flame lengths and speeds are approximate, referred to burners fueled by natural gas, placed in open air, working at stoichiometric ratio and at nominal capacity.

In special applications, a mono electrode is used for ignition and flame detection or an electrode for ignition and a UV photocell for flame detection.

Model	Type of refractory block (1)	Capacity [kW]	Flame length [mm]	Diameter of refractory block [mm]	Flue gas outlet speed @1500°C [m/s]						
					a 0m	a 0,5m	a 1m	a 1,5m	a 2m	a 2,5m	a 3m
12 EXDF	M	102	300÷500	106	60	38	19	13	9	7,5	6
	H			50	90	48	24	17	12	9	7,5
16 EXDF	M	203	600÷800	129	60	52	26	19	14	11	10
	H			74	90	58	33	22	17	14	12
24 EXDF	M	407	1000÷1250	190 (129)	60	53	27	20	15	12	11
	H			108	90	74	40	27	21	17	14
32 EXDF	M	814	1250÷1500	190	60	52	28	22	17	14	12
	H			149	90	62	36	25	19	15	13
48 EXDF	M	1628	2000÷2500	280	60	54	32	27	21	19	16
	H			212	90	63	38	27	21	16	14
4X48 EXDF*	M	6512	2000÷2500	4X280	60	55	34	28	22	20	17

(*) Where higher potential with small flame lengths is needed other multiblock models are available on request.

- ¹ M: Flame output speed 50÷60 m/s
H: Flame output speed 80÷90 m/s

BURNER PERFORMANCE

Potential, lengths and flame speed are related to natural gas-fueled burners (8600 kcal / Nm³), placed

in the combustion chamber at zero pressure above sea level, working with the 10% of excess air.

- Chamber temperature 1100°C.
- Diesel oil fuel
- Natural gas fuel.

MAXIMUM OIL CAPACITY

			Burner model				
			12 EXDF	16 EXDF	24 EXDF	32 EXDF	48 EXDF
Max Capacity	Burner capacity	[kW]	102	203	407	814	1628
	Combustion air flow	[Nm ³ /h]	100	195	395	790	1630
	Atomizing air flow	[Nm ³ /h]	10	20	40	80	160
	Gas flow	[Nm ³ /h]	-	-	-	-	-
	Oil flow	[l/h]	10	20	40	80	160
	Combustion air pressure	[mbar]	70	70	70	70	70
	Atomizing air pressure	[mbar]	200	200	200	200	200
	Oil pressure	[bar]	2,1	2,1	2,1	2,1	2,1

MINIMUM OIL CAPACITY

			Burner model				
			12 EXDF	16 EXDF	24 EXDF	32 EXDF	48 EXDF
Min. Capacity	Burner capacity	[kW]	17	34	68	135	270
	Combustion air flow	[Nm ³ /h]	9	17	34	68	138
	Atomizing air flow	[Nm ³ /h]	10	20	40	80	160
	Gas flow	[Nm ³ /h]	-	-	-	-	-
	Oil flow	[l/h]	1,7	3,4	6,8	13,5	27
	Combustion air pressure	[mbar]	1	1	1	1	1
	Atomizing air pressure	[mbar]	200	200	200	200	200
	Oil pressure	[bar]	0,06	0,06	0,06	0,06	0,06

BURNER PERFORMANCE

MAXIMUM NATURAL GAS CAPACITY

			Burner model				
			12 EXDF	16 EXDF	24 EXDF	32 EXDF	48 EXDF
Max. Capacity	Burner capacity	[kW]	92	183	366	733	1465
	Combustion air flow	[Nm ³ /h]	101	201	402	806	1610
	Atomizing air flow	[Nm ³ /h]	-	-	-	-	-
	Gas flow	[Nm ³ /h]	9,2	18,3	36,6	73,3	147
	Oil flow	[l/h]	-	-	-	-	-
	Combustion air pressure	[mbar]	70	70	70	70	70
	Atomizing air pressure	[mbar]	-	-	-	-	-
	Oil pressure	[bar]	-	-	-	-	-
	gas Δp	[mbar]	10	10	10	10	10

MINIMUM NATURAL GAS CAPACITY

			Burner model				
			12 EXDF	16 EXDF	24 EXDF	32 EXDF	48 EXDF
Min. Capacity	Burner capacity	[kW]	12	23	45	92	185
	Combustion air flow	[Nm ³ /h]	13	25	50	102	203
	Atomizing air flow	[Nm ³ /h]	-	-	-	-	-
	Gas flow	[Nm ³ /h]	1,2	2,3	4,5	9,2	18,5
	Oil flow	[l/h]	-	-	-	-	-
	Combustion air pressure	[mbar]	1,1	1,1	1,1	1,1	1,1
	Atomizing air pressure	[mbar]	-	-	-	-	-
	Oil pressure	[bar]	-	-	-	-	-
	gas Δp	[mbar]	0,2	0,2	0,2	0,2	0,2

APPLICATION EXAMPLES

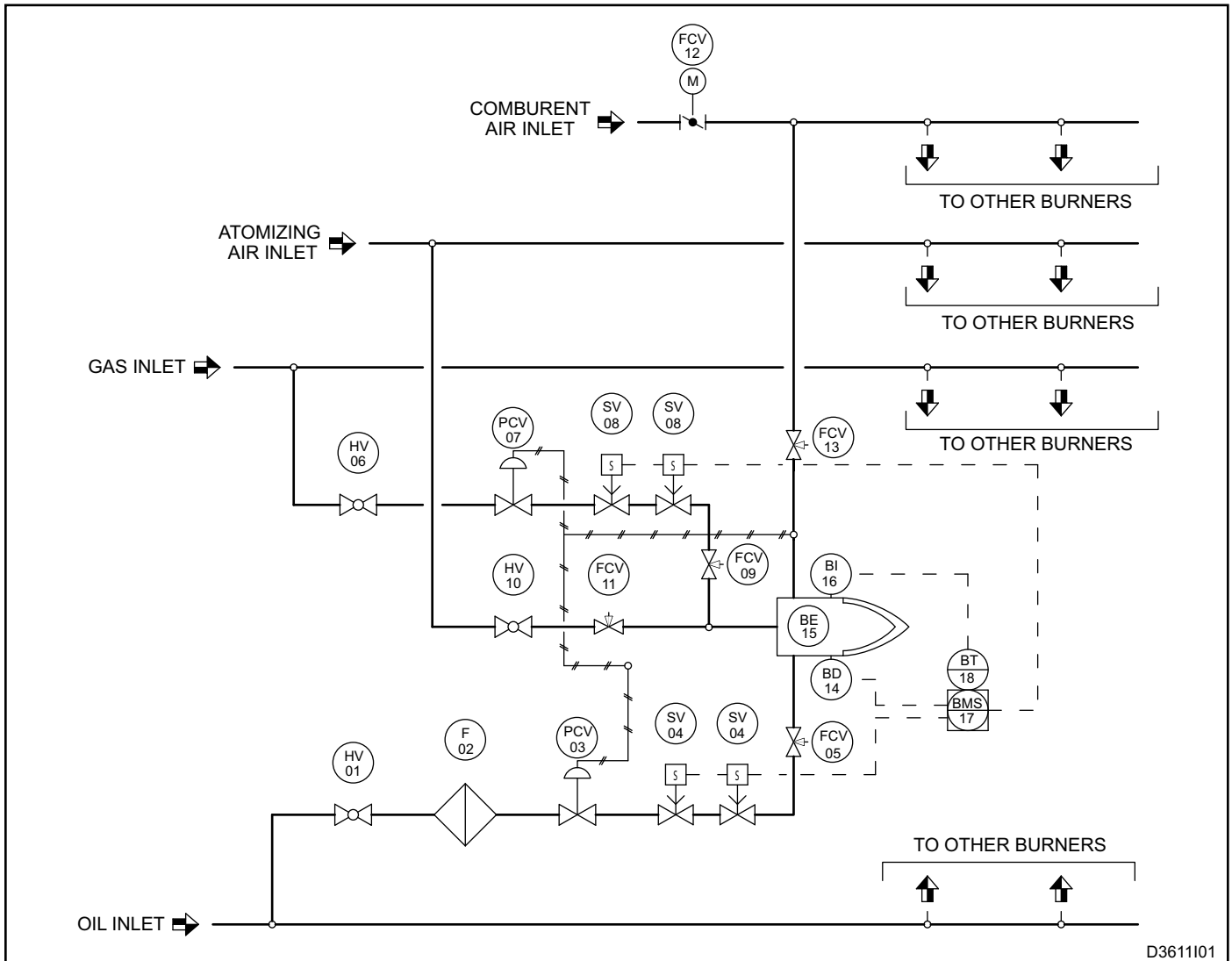

D3611I01

Pos.	Description	Included	Not included
HV 01	Oil interception valve		X
F 02	Oil filter		X
PCV 03	Oil pressure regulator		X
SV 04	Oil safety valve		X
FCV 05	Oil interception valve	X	
HV 06	Gas interception valve		X
PCV 07	Zero governor		X
SV 08	Gas safety valve		X
FCV 09	Gas adjuster		X
HV 10	Atomizing air interception valve		X
FCV 11	Atomizing air regulation valve		X
FCV 12	Combustion air regulation valve		X
FCV 13	Manual air regulation valve		X
BD 14	Flame detection		X
BE 15	Burner		X
BI 16	Burner ignition		X
BMS 17	Flame control		X
BT 18	Ignition transformer		X

WARNINGS

- The burners of EXDF series are intended for use in fixed installation. If mobile installations are needed (bell furnaces, etc ...) it is necessary to evaluate the possibility of any damages determined by the movement of the actual furnace
- Burner ignition must be always performed at minimum power, then modulating towards the maximum, facilitating ignition and reducing outlet overpressure.
- Moving from minimum to maximum power, and vice versa, should be gradual and not instantaneous.
- For all low-temperature applications (up to 750 °C), burner ignition and the control of the fuel gas solenoid valves must be performed by a certified burner control device.
- It is always necessary to use flexible couplings in the presence of preheated air.
- To avoid possible damage to burners, make sure that the blower does not send them air that may be fouled by combustion products, oils, solvents or other. To avoid these phenomena from taking place, possibly install the blower or the suction duct outside the establishment and far from the exhaust pipes.
- Check the correct connection of the feeding lines after installation. Before switching the burner on, check that the combustion air and fuel gas pressure values are correct.
- The burner can only function within the indicated power range. Functioning at lower or higher power could compromise the burner performance as well as its life span. In which case, the general warranty conditions will automatically expire and ESA will not be held responsible for any damage to persons or objects.
- If there is trouble with other devices during the burner start up phase, use the connector with anti disturbance filter for the high-tension (HT) cable connection of the ignition electrode.
- Avoid burner ignition close to each other so as not to heat the ignition command system devices (solenoid valves and transformers). Prewash time lapse + first safety time lapse + min. of 5 sec. = time lapse between one ignition and another. (however, do not attempt more than 2 ignitions during a 30sec. time lapse).
- Make sure the power supply is TURNED OFF when intervening on the burner and its devices. In case of burner malfunctioning, follow the indications in the 'Maintenance' chapter of the present manual or contact ESA-PYRONICS assistance.
- Any modification or repair done by third parties can compromise the application safety and automatically causes the general warranty conditions to expire.

INSTALLATION

The EXDF burners are generally installed on the furnace walls. Roof mounting is unadvisable; in any case, if it is necessary, please specify during the order phase.

The light needed for the burner housing must have sufficient open space around the refractory block for the ceramic fibre insulation (which is already supplied with the burner). Please refer to the OVERALL DIMENSIONS chapter for this process.

The use of flexible hoses and / or compensators for connection of the air and gas lines is mandatory. The air and gas inlets have flanges (threaded or to be welded) and can freely rotate at a 90° angle.

We recommend you install the refractory block with the holes for the pilot burner and flame detection photocell on the upper part.

Installation with the holes at the bottom could create problems.

1 - Insert on the furnace wall (**pos.01**).

2 - Lift the burner (**pos.03**) and fix it to the studs (**pos.02**) with nuts (**pos.04**), checking that the ceramic insulation surrounding the block does not get damaged while inserting the block in the hole, and that the gasket does not move or get deformed.

3 - Tighten the fixing nuts the furnace wall flange leaving them loose to allow the burner refractory block to float during heating.

4 - Connect the air and gas lines of the burner with the fixing flanges.

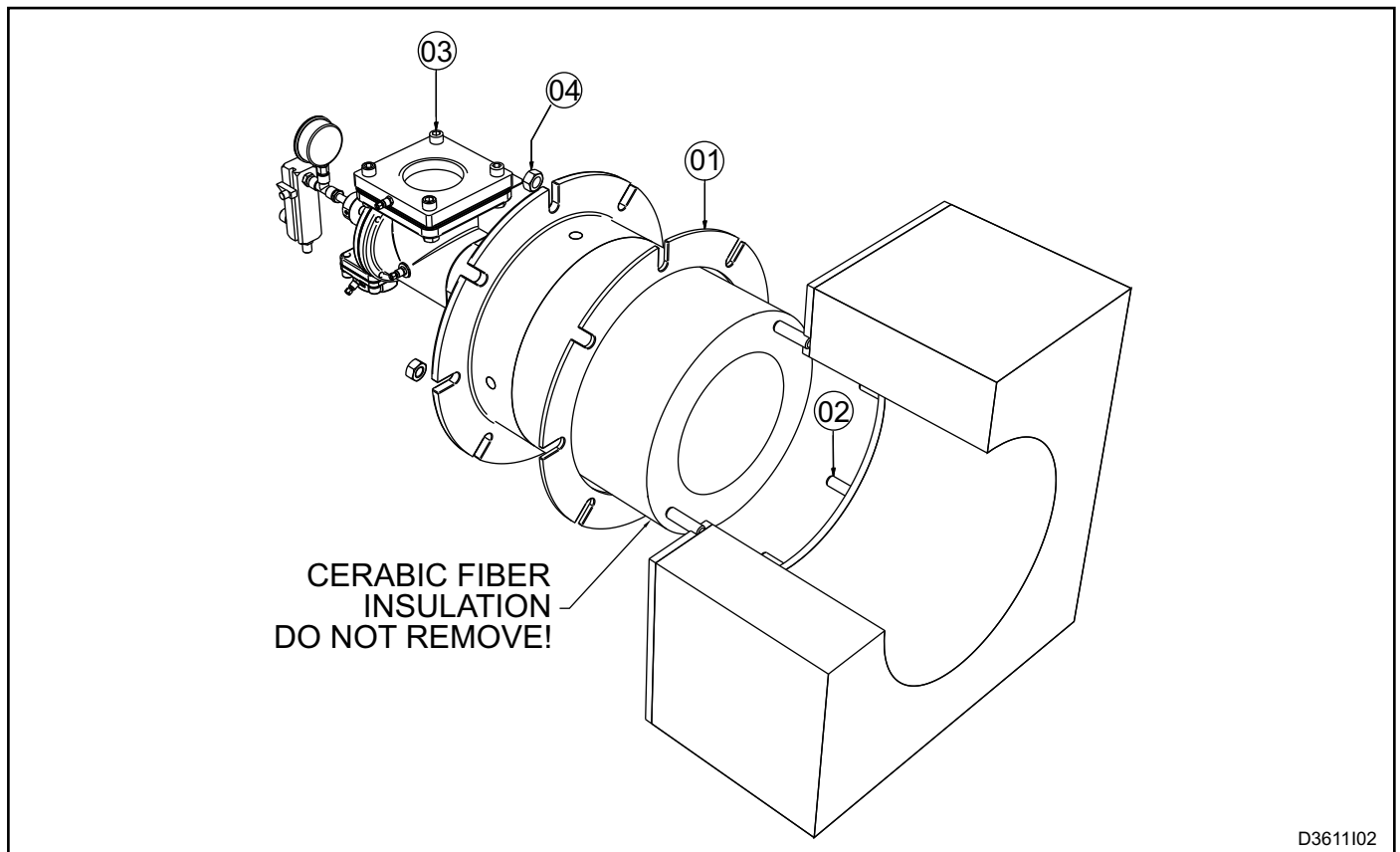

5 - Carry out the first furnace heating following the appropriate refractory material drying curves.

6 - Once the maximum operating temperature is reached, finally tighten the fixing nuts.

7 - After heating the first time, immediately repair possible cracks or small damage. Generally the furnace walls around the burner must be inspected regularly and all cracks are to be repaired or patched up. This avoids hot gas leaks inside the cracks damaging the metallic parts of

the furnace or burner.

8 - If blocks with metal casing are used, the metal casing must be appropriately protected from the high temperature of the furnace.

9 - Burner housing must be built with suitable burner supports to prevent possible collapsing of the refractory block. The refractory block must not protrude from the wall. If it does, provide suitable spacers to move it back to its position compared to the inner furnace wall.

IGNITION - SETTING

The operations indicated in the following chapter must be carried out by expert technicians or qualified staff. The inobservance of the instructions could generate dangerous conditions.

- 1** - Check that the combustion air pressure on the blower outlet, gas and fuel oil feeding pressures are within the allowed range.
- 2** - Regulate the operating and intervention pressures of the combustion plant safety devices whether there is one per burner or one general device for the entire combustion plant such as: gas pressure reducer, shut off valve, pressure relief valve, pressure switches etc. Simulate the intervention of all the safety devices including the high temperature safety intervention checking that the fuel shut off devices act correctly.
- 3** - Place the air regulation valve in the maximum opening position and adjust, via the gate valve referring to the values indicated in the "Burner Performance" chapter for the maximum capacity on pages 04 and 05.
- 4** - Place the motorized air regulation valve in the minimum opening position and adjust the opening to obtain (on the burner input) the pressure related to the minimum power.
- 5** - Activate the burner control device and run a few attempts to switch on the pilot burner (*) until the burner lights up. During the ignition attempts, act on the gas or oil control valve and, starting from the totally closed position, open it gradually until burner ignition is obtained.
- 6** - Place the air regulation motorized valve at its maximum opening position and adjust, via the gas and oil regulation valve, the maximum fuel flow, checking the differential pressure that is created on the calibrated gas flange or the pressure on the coil lance input. The calibration at minimum is done with the air valve at its minimum, acting on the adjustment screw placed inside the pneumatic regulator.
- 7** - Check again that, at minimum and maximum power, the burner air inlet pressure corresponds to what is indicated in the "Burner performance" chapter. It is possible that, with the burner running, the values are different in comparison to those with burner off.
- 8** - With the furnace at the correct temperature, carry out an analysis of the combustion products on the burner chimney with a portable analyzer and if necessary adjust the air and gas pressure (Reference value of O₂ at maximum power of 2÷4%, at minimum power 3÷6%).
- 9** - Possibly with all the burners running at the same power, analyze the combustion products in the chamber (where possible).
- 10** - Perform repeated ignition attempts at minimum burner power with temperature variations at maximum to check ignition reliability and flame stability during regulation.

(*) For ignition and setting of the pilot burner refer to the data sheet E3280.

TRANSITION FROM OPERATION WITH OIL TO OPERATION WITH GAS

The EXDF burners can work with both liquid fuel (oil with a maximum viscosity of 3°E) as well as gas fuel (class

1/2/3). The transition from one type of fuel to the other takes place quickly and respecting the instructions below:

TRANSITION FROM OIL TO GAS

- 1 - Close the manual interception valve on the fuel oil line
- 2 - Close the manual interception valve on the atomizing air line.
- 3 - Loosen the grub screw (pos. 01) to unblock the movement of the oil lance (pos.02).
- 4 - Pull the oil lance (pos. 02) until reaching the maximum extractable position.
- 5 - Screw on the grub screw (pos. 01) until blocking the oil lance in the maximum extractable position.
- 6 - Open the manual interception valve on the fuel gas line.
- 7 - Adjust the gas flow according to the indications contained in the BURNER PERFORMANCE section.

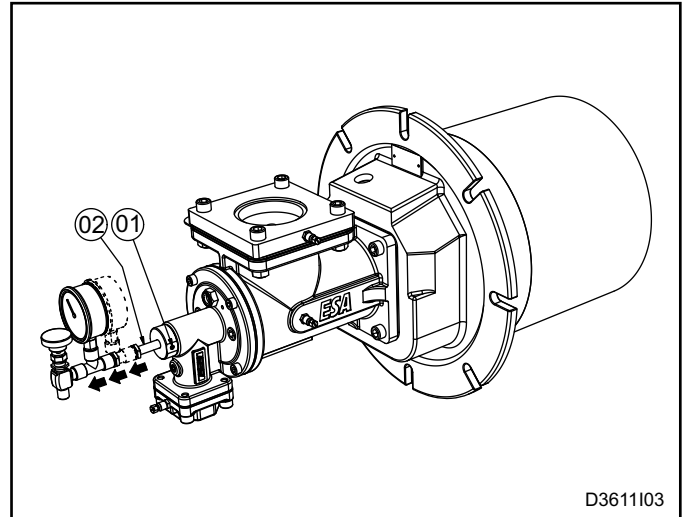

TRANSITION FROM GAS TO OIL

- 1 - Close the manual interception valve on the fuel oil line.
- 2 - Loosen the grub screw (pos. 01) to unblock the movement of the oil lance (pos.02).
- 3 - Release the oil lance (pos.02) oil up to the stop position (minimum extraction position).
- 4 - Screw on the grub screw (pos. 01) until blocking the oil lance in place.
- 5 - Open the manual interception valve on the fuel gas line.
- 6 - Open the manual shut-off valve on the air atomization line.
- 7 - Adjust the atomizing air and fuel oil flow according to the instructions contained in the BURNER PERFORMANCE section.

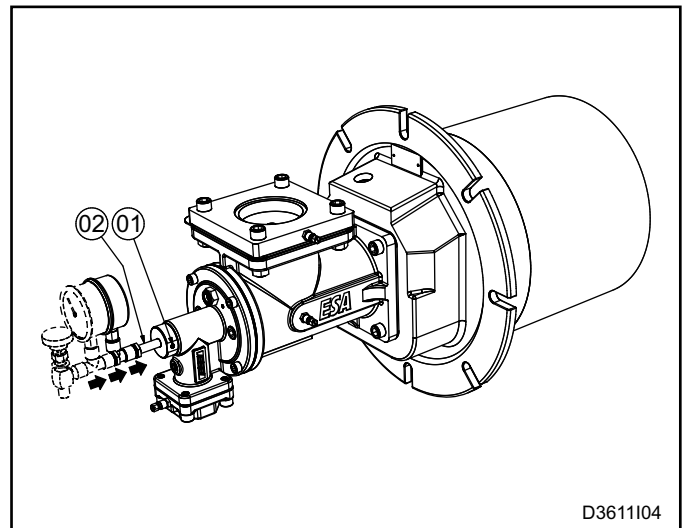

GENERAL MAINTENANCE PLAN

Operation	Type	Advised time	Notes
Pilot burner electrode high voltage connector	O	annual	verify integrity of the outer plastic and oxidation of the internal connector and the electrode terminal.
Pilot burner ignition electrode	O	annual	replace in the case in which the terminal Kanthal is worn.
Integrity of refractory block	S	every six months	from the inside check the presence of any cracks in the refractory material every time the furnace is stopped for maintenance. If there are cracks they must be filled with appropriate refractory material or sealant.
Cleaning of the photocellglass	O	every six months	reduce to quarterly in dusty environments.
Photocell replacement	O	10.000 h. of operation	in any case every 2 years.
Gascket replacement on gas side (*)	O	every two years	see note.
Burner setting	O	annual	repeat all the steps on "Ignition and Setting" chapter.
Cleaning of oil lance	O	every six months	disassemble the elements of the nozzle and clean it from any deposits. Clean more often in the case of oils not adequately filtered.

NOTES:

Key: O = ordinary / S = extraordinary

(*) We advise you to replace the gas side gaskets after every time the gas feeding line is disassembled and to use high temperature gaskets.

ORDINARY MAINTENANCE

For correct dismantling and better maintenance of EXDF burners, meticulously follow the instructions below with the plant turned off.

CLEANING OF PHOTOCELL GLASS

- 1 - Make sure the burner control device is not connected.
- 2 - Disconnect power supply to the photocell (**pos. 01**) and the cooling line (where present **pos. 07**).
- 3 - Unscrew the aluminum pipe fitting (**pos. 06**) at the base of the gas collector, removing the photocell with its

spacer.

4 - Unscrew the aluminum pipe fitting from the insulation teflon connector (**pos. 03**) and pull out the quartz watch glass (**pos. 05**).

5 - Clean the quartz watch glass with a soft cloth and reassemble everything, taking care to check the correct position of the glass and seals (**pos. 04**) between the aluminum spacer and teflon, before tightening.

6 - Restore the cooling pipe and the electrical connection.

7 - Check the correct flame detection by the photocell.

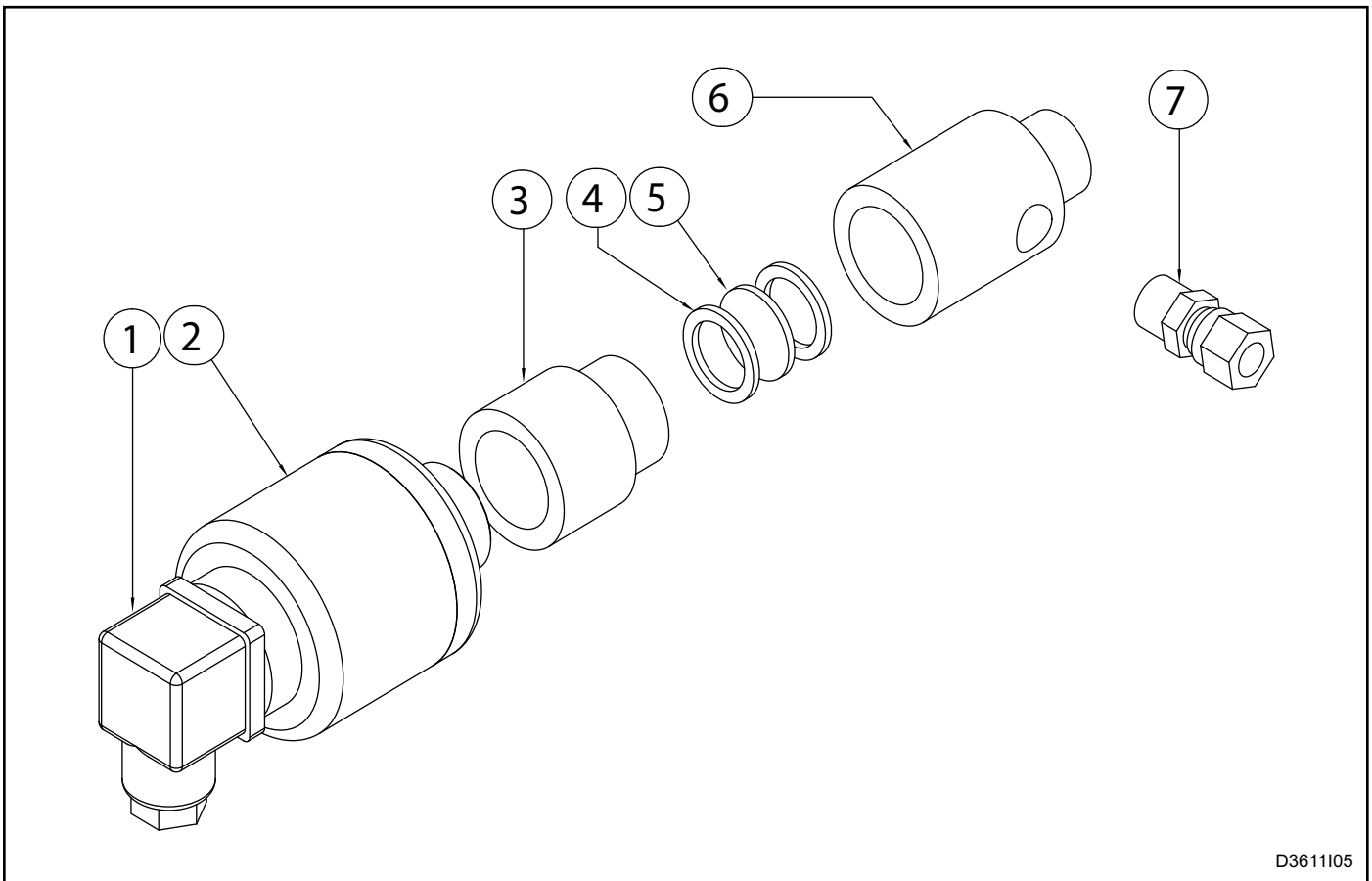

D361105

EXTRAORDINARY MAINTENANCE

For correct dismantling and better maintenance of NM burners, meticulously follow the instructions below with the plant turned off.

BURNER IN LOCKOUT

In burner lockout conditions refer to the instructions of the burner control device and the relative manual to identify the cause. The following are the main cases:

■ **Illegal flame detection:** lockout due to the detection of an illegal flame signal during the phases prior to ignition or following the shutdown. The causes are to be found in the detection system (faulty sensor or presence of humidity), or in a gas drawn by the safety valve that allows the burner to remain turned on.

■ **Ignition failed:** lockout due to missing flame formation during start-up. The causes are to be found in the ignition system (spark absence, faulty or not in the correct position) electrodes, the incorrect adjustment of the fuel flow and combustion, or in the detection system (faulty sensor or interrupted cables). Specifically, in the first two

cases the flame does not ignite, whilst in the last case, the flame forms but the burner control device is not able to detect it.

■ **Flame signal loss:** lockout due to flame signal loss during the normal operation of the burner. The causes are to be found in the regulation of the combustion air and fuel flows (rapid changes in flow, control out of range) or in the detection system (faulty, dirty or badly positioned sensors).

PHOTOCELL REPLACEMENT

- 1 - Make sure the burner control device is not connected.
- 2 - Disconnect power supply to the photocell (**pos. 01**) and the cooling line (where present).
- 3 - Unscrew the aluminum pipe fitting at the base of the gas collector (**pos. 02**), removing the photocell with its spacer.
- 4 - Screw in the same position the new component after checking the correct position of the insulating glass between the aluminum and teflon spacer.
- 5 - Restore the cooling hoses and electrical connection.
- 6 - Check the correct flame detection by the photocell.

OVERALL DIMENSIONS - EXDF ROUND REFRACTORY BLOCK

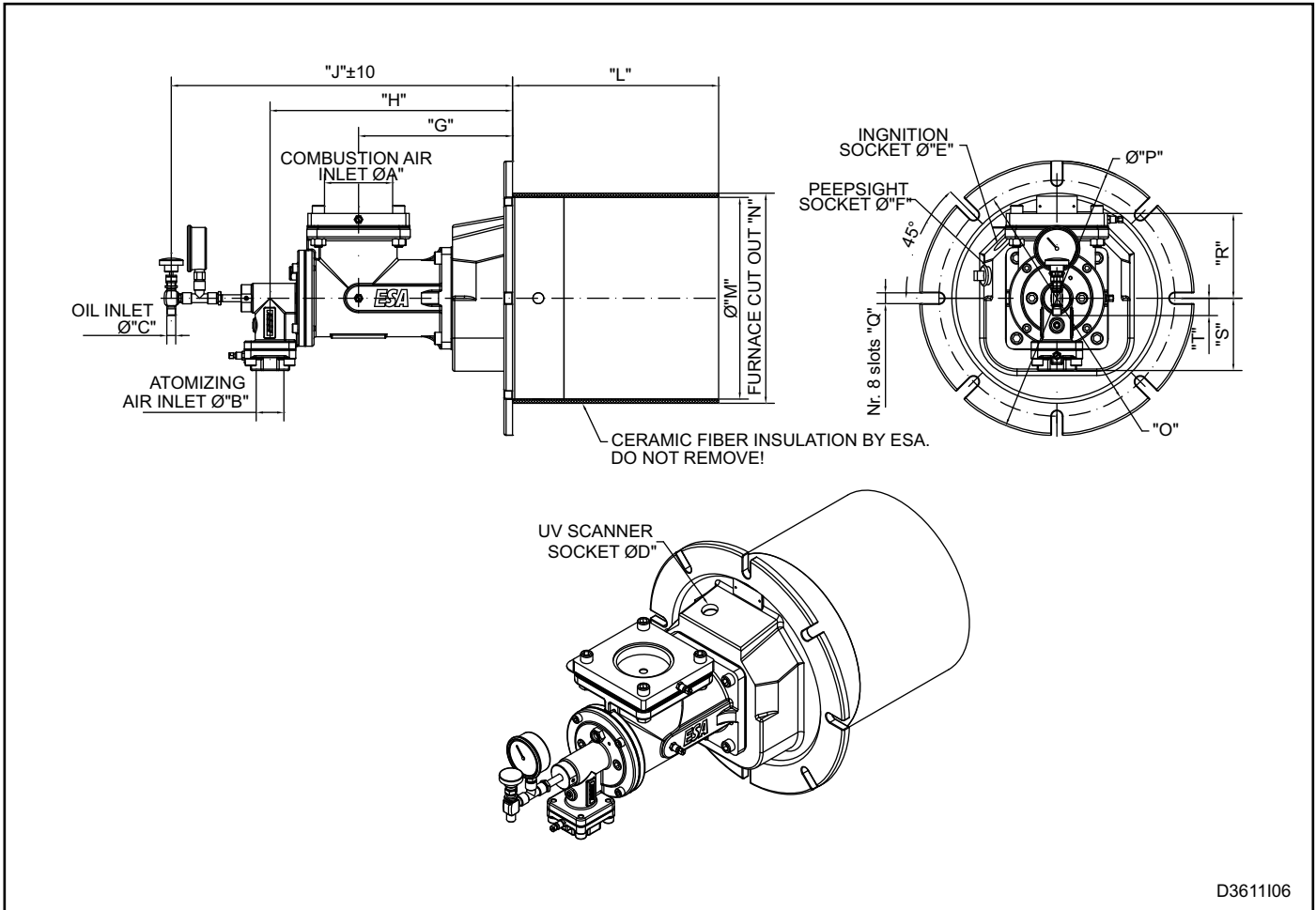

D3611106

Model	$\varnothing A$	$\varnothing B$	$\varnothing C$	$\varnothing D$	$\varnothing E$	$\varnothing F$
12EXDF	G 1.1/2"	G 3/4"	Rp 1/8"	G 3/4"	G 3/4"	G 3/4"
16EXDF	G 2"	G 1"	Rp 1/8"	G 3/4"	G 3/4"	G 3/4"
24EXDF	DN80	G 1.1/2"	Rp 1/4"	G 3/4"	G 1"	G 3/4"
32EXDF	DN100	G 2"	Rp 1/4"	G 3/4"	G 1"	G 3/4"
48EXDF	DN150	DN80	Rp 1/4"	G 3/4"	G 1"	G 3/4"

Model	G mm	H mm	J mm	L mm	$\varnothing M$ mm	$\varnothing N$ mm	O mm	P mm	Q mm	R mm	S mm	T mm	Massa Kg
12EXDF-R	117	200	337	228	178	191	□ 222	□ 254	14	87	80	21	23,1
16EXDF-R	120	228	364	254	203	216	\varnothing 289	\varnothing 330	16	101	80	21	31,5
24EXDF-R	228	359	506	305	298	311	\varnothing 349	\varnothing 406	16	126	107	26	73,2
32EXDF-R	228	359	506	305	298	311	\varnothing 349	\varnothing 406	16	122	107	26	72,5
48EXDF-R	233	464	618	330	400	412	\varnothing 457	\varnothing 508	16	156	130	26	130,5

OVERALL DIMENSIONS - EXDF SQUARE REFRACTORY BLOCK

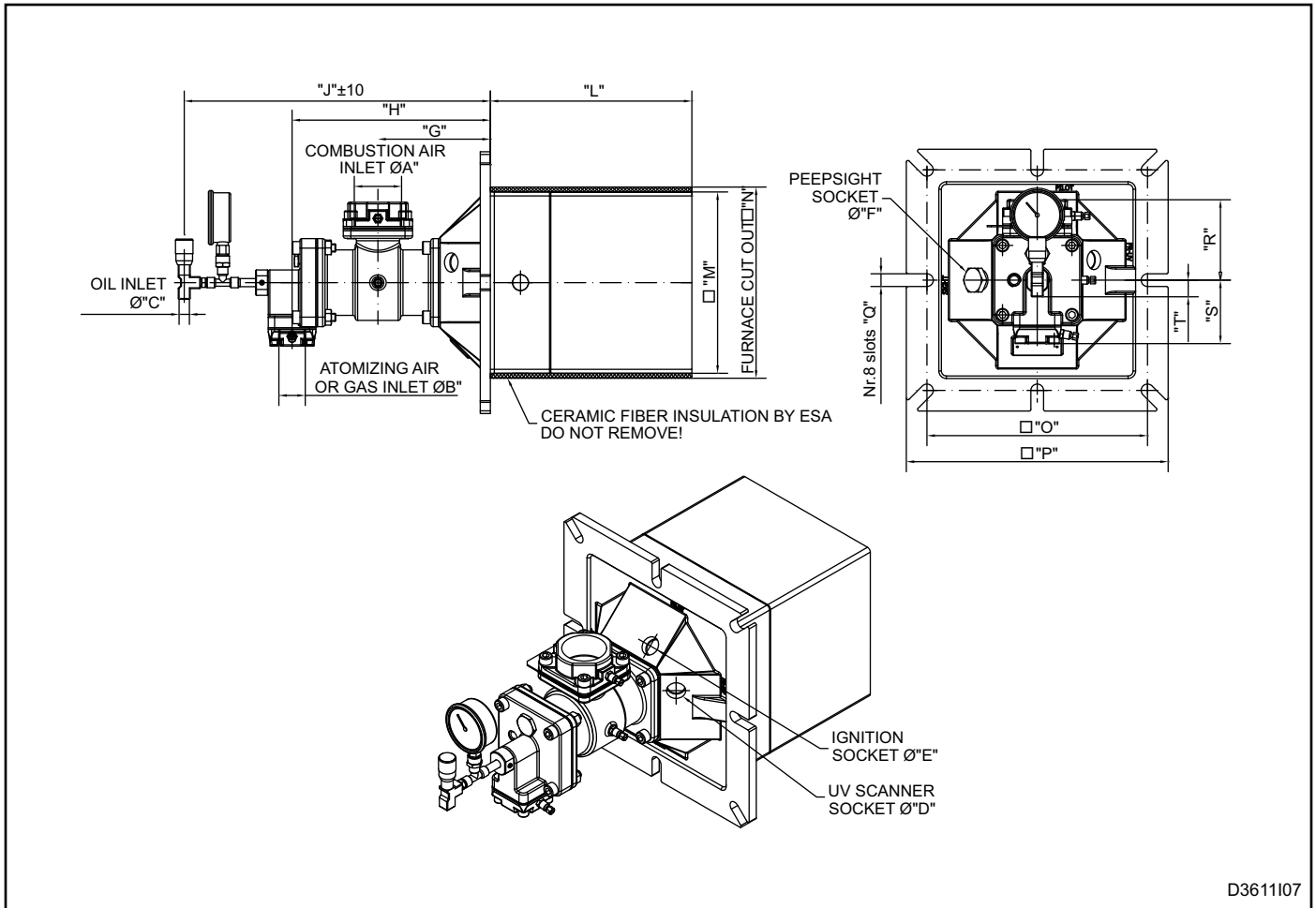

Model	Ø "A"	Ø "B"	Ø "C"	Ø "D"	Ø "E"	Ø "F"
12EXDF	G 1.1/2"	G 3/4"	Rp 1/8"	G 3/4"	G 3/4"	G 3/4"
16EXDF	G 2"	G 1"	Rp 1/8"	G 3/4"	G 3/4"	G 3/4"
24EXDF	DN80	G 1.1/2"	Rp 1/4"	G 3/4"	G 1"	G 3/4"
32EXDF	DN100	G 2"	Rp 1/4"	G 3/4"	G 1"	G 3/4"
48EXDF	DN150	DN80	Rp 1/4"	G 3/4"	G 1"	G 3/4"

Model	G mm	H mm	J mm	L mm	□ M mm	□ N mm	O mm	P mm	Q mm	R mm	S mm	T mm	Massa Kg
12EXDF-R	117	200	337	219	178	191	□ 222	□ 254	14	87	80	21	27,6
16EXDF-R	142	250	386	254	229	241	□ 278	□ 330	16	101	80	21	48,1
24EXDF-R	190	231	468	241	419	432	□ 464	□ 508	16	126	107	26	136,8
32EXDF-R	190	231	468	241	419	432	□ 464	□ 508	16	122	107	26	136,1

OVERALL DIMENSIONS - 48 EXDF MULTI TUNNEL MODEL

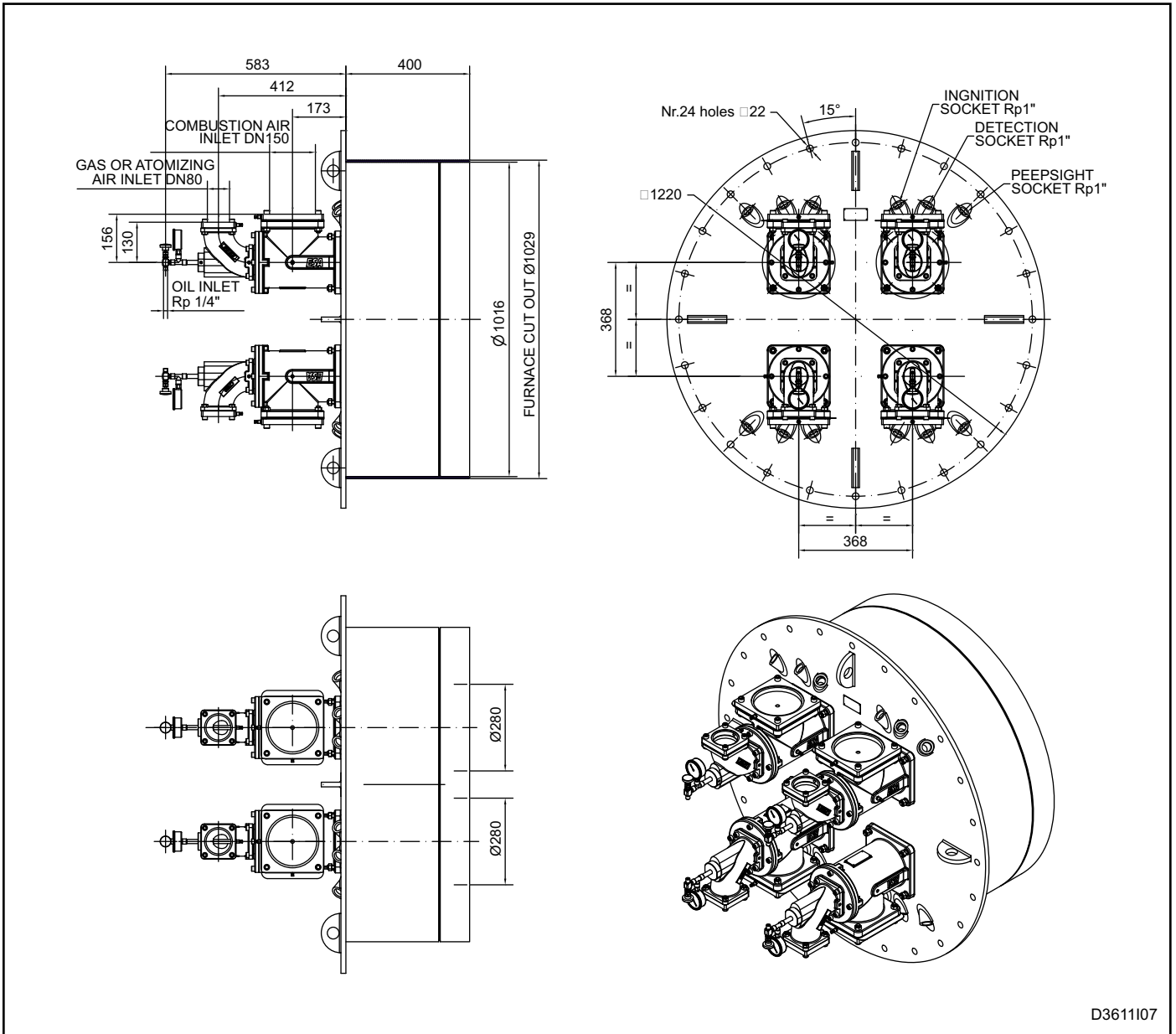

D361107

ORDERING CODE- COMPLETE BURNER

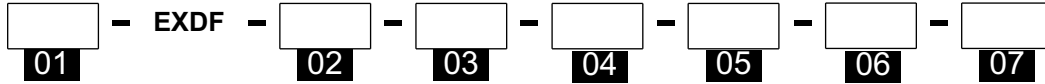

MODEL		01
12EXDF	12	
16EXDF	16	
24EXDF	24	
... (see capacity table)	

GAS ADJUSTER		02
With gas adjuster	GA*	
Flange	F	

FUEL		03
Methane	CH4	
LPG	GPL	
Poor gas (1)	GP	

04 LOCKOUT TYPE (2)	
Medium velocity	M
High velocity	H

05 REFRACTORY BLOCK	
Round block	R
Square block	S

06 ALLOY JACKET REFRACTORY BLOCK	
Without jacket	2
With jacket	D

07 IGNITION	
Electrode	E
Pilot	P

ORDERING CODE - ONLY REFRACTORY BLOCK

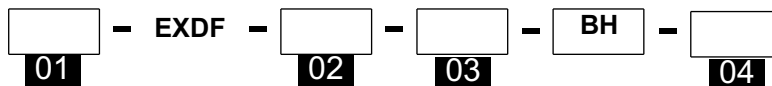

MODEL		01
12EXDF	12	
16EXDF	16	
24EXDF	24	
... (see capacity table)	

TYPE OF BLOCK (2)		02
Medium velocity	M	
High velocity	H	

03 REFRACTORY BLOCK	
Round block	R
Square block	S

04 ALLOY JACKET REFRACTORY BLOCK	
Without jacket	2
With jacket	D

(*) The codes marked with an asterisk identify the standards.

Notes:

¹ Particular performance according to gas characteristics.

² see "Parameter potential and flame length" table

ESA worldwide distribution



AUTHORIZED DISTRIBUTION STAMP



If you have any doubt about the qualification or identity of the distributor, please contact us directly at esa@esacombustion.it



© 2012 ESA S.p.A. Company under the management and coordination of SIAD S.p.A.
All rights reserved.

The information contained herein is offered for use by technically qualified personnel at their discretion and risk without warranty of any kind.

We regularly update our data, for updated data please visit our web site www.esapyronics.com

Printed in Italy
CATukR00/12

Head Office and Factory

ESA S.p.A. Company under the management and coordination of SIAD S.p.A.

Via E. Fermi, 40
I-24035 Curno (Bergamo)
ITALY

esa@esacombustion.it
www.esapyronics.com

Tel.
+39 035 6227411

Fax
+39 035 6227499

Share Capital euro 153.111,00 paid up - Fiscal Nr.: 03428410157 - V.A.T. Nr.: (IT) 00793030164
Reg. Impr. Bg Nr.: 03428410157 - R.E.A. BG-173124 - Export: BG0061150

Pyronics International s.a.
Zoning Industriel, 4ème rue
B-6040 Jumet
BELGIUM

marketing@pyronics.be
www.esapyronics.com

Tel.
+32 71 256970

Fax
+32 71 256979

www.esapyronics.com